

CLOSED

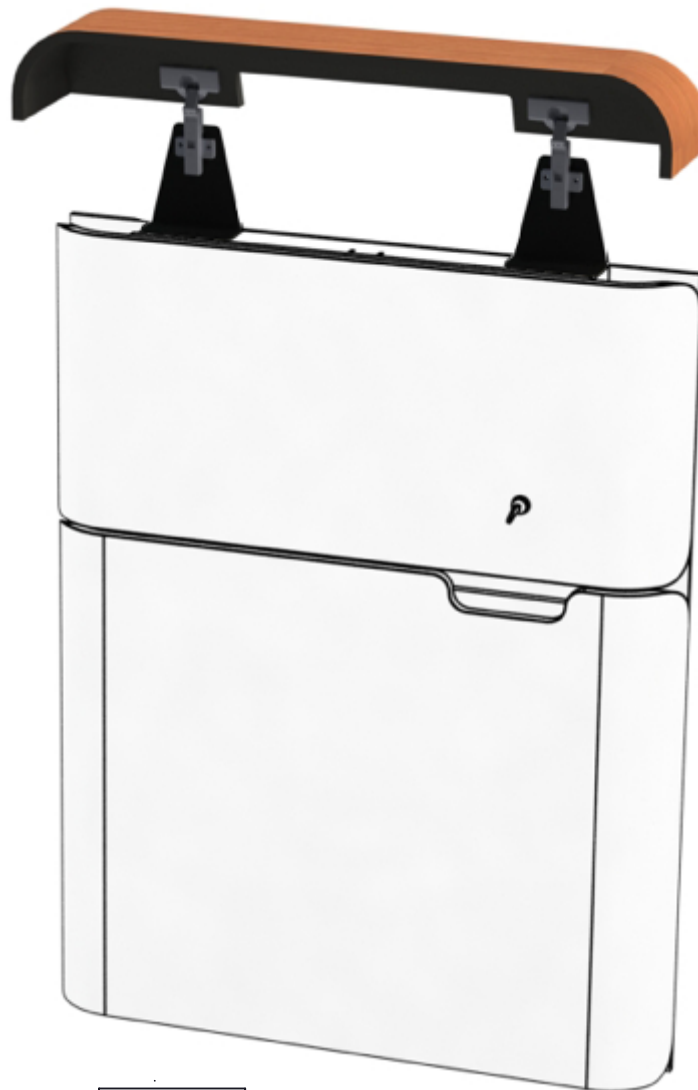

OPEN

AVAILABLE COLORS

FROSTY WHITE 1573-60	FUSION MAPLE 7909-60	BANNISTER OAK 7806-60	FONTHILL PEAR 10745-60	WILD CHERRY 7054-60	BRIGHTON WALNUT 7922-60
----------------------------	----------------------------	-----------------------------	------------------------------	---------------------------	-------------------------------

*WILD CHERRY
SHOWN



PROXIMITY

ALL DIMENSIONS ARE IN INCHES
UNLESS NOTED OTHERWISE.
DESIGN SUBJECT TO CHANGE
WITH EQUIPMENT SPECIFICATIONS.
ALL INFORMATION ON THIS
DRAWING IS PROPRIETARY AND
MAY NOT BE USED WITHOUT
PERMISSION FROM PROXIMITY
SYSTEMS, INC. © 2016.

DRW BY: ZG
DRW DATE: SEP-27-2016
REV BY:
REV DATE:
REV: A

PART NAME: 4" SLOPPED CABINET TOP
PART NO: AC-CTOP-4-XXXX
DESCRIPTION: TOP FOR CXT SLIM
WORK STATION

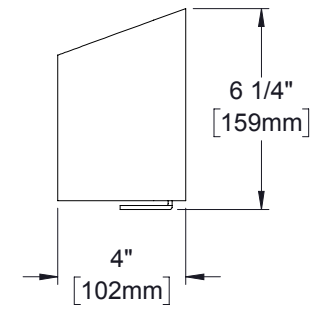
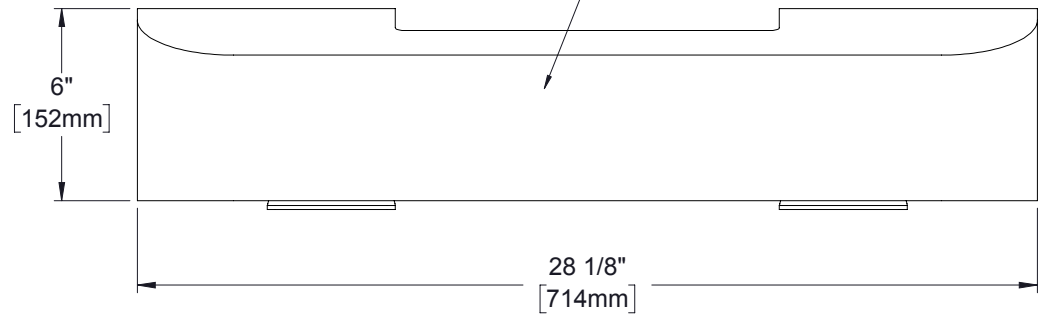
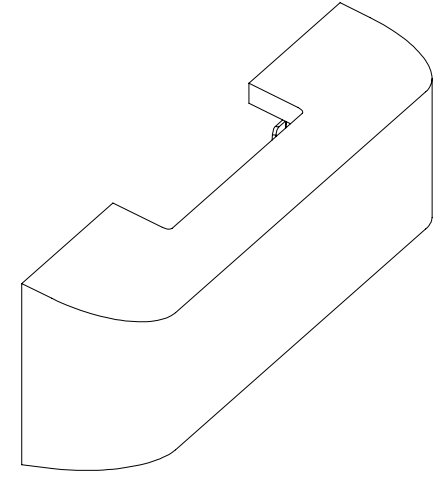

PROXIMITY[®]

ALL DIMENSIONS ARE IN INCHES UNLESS NOTED OTHERWISE. DESIGN SUBJECT TO CHANGE WITH EQUIPMENT SPECIFICATIONS. ALL INFORMATION ON THIS DRAWING IS PROPRIETARY AND MAY NOT BE USED WITHOUT PERMISSION FROM PROXIMITY SYSTEMS, INC. © 2016.

DRW BY: ZG
 DRW DATE: SEP-27-2016
 REV BY:
 REV DATE:
 REV: A

COMPONENTS INCLUDED	
ITEM NO.	COMPONENTS
1	HINGES
2	SUPPORT BRACKET
3	TOP
4	N/A
5	N/A